

FEATURES

- **Forced guide contact structure** (EN50205 ClassA TÜV recognized)

- **Slim profile (mm inch)**

Compact size with slim profile relay reduces substrate size.

[4-poles type] 40 (L)×13 (W)×24 (H)
1.575 (L)×.512 (W)×.945 (H)

[6-poles type] 50 (L)×13 (W)×24 (H)
1.969 (L)×.512 (W)×.945 (H)

- **Built-in LED indication type available**

Built-in LED eliminates need for design and mounting of separate LED circuit. This cuts costs and saves labor.

- **Fast response time is achieved (8 ms or less).**

Circuit is quickly opened to ensure safety.

- **High shock resistance (Functional: Min. 200m/s²)**

Improved anti-shock properties meaning that the relay can be safely used in high shock and vibration environments such as in machine tools and other factory equipment.

- **PC board sockets also available (4 and 6-poles)**

- **Lineup also includes DIN terminal socket with finger protect construction. (4 and 6-poles)**

TYPICAL APPLICATIONS

- Machine tools
- Robots
- Safety PLCs
- Circuits with stringent safety standard requirements such as those in motor vehicle production equipment.

RoHS Directive compatibility information
<http://www.nais-e.com/>

SPECIFICATIONS

Contact

Item		4-poles	6-poles	
Contact arrangement		2 Form A/2 Form B 3 Form A/1 Form B	4 Form A/2 Form B 5 Form A/1 Form B 3 Form A/3 Form B	
Initial contact resistance, max. (By voltage drop 6 V DC 1 A)		100 mΩ		
Contact material		Gold-flashed AgSnO ₂ type		
Rating (resistive load)	Nominal switching capacity	6 A 250 V AC, 6 A 30 V DC		
	Max. switching power	1,500 VA, 180 W		
	Max. switching voltage	250 V AC, 30 V DC		
	Max. switching current	6 A (Reduce by 0.1 A/°C for temperatures 70 to 85°C.)		
	Min. switching capacity (Reference value) #1	1 mA 5 V DC		
Expected life (min. operations)	Mechanical (at 180 cpm)	10 ⁷		
	Electrical	250 V AC 6 A resistive load:	10 ⁵ (at 20 cpm)	
		30 V DC 6 A resistive load:	10 ⁵ (at 20 cpm)	
		250 V AC 1 A resistive load:	5×10 ⁵ (at 30 cpm)	
		30 V DC 1 A resistive load:	5×10 ⁵ (at 30 cpm)	
		[AC 15] 240 V AC 2 A inductive load:	10 ⁵ (at 20 cpm, cosφ = 0.3)	
[DC 13] 24 V DC 1 A inductive load:	10 ⁵ (at 20 cpm, L/R = 48 ms)			

#1 This value can change due to the switching frequency, environmental conditions, and desired reliability level, therefore it is recommended to check this with the actual load.

Coil

	4-poles	6-poles
	2 Form A/2 Form B 3 Form A/1 Form B	4 Form A/2 Form B 5 Form A/1 Form B 3 Form A/3 Form B
Nominal operating power	360 mW	500 mW

SF

Characteristics (at 20°C 68°F)

Item	4-poles		6-poles	
	2 Form A/2 Form B 3 Form A/1 Form B		4 Form A/2 Form B 5 Form A/1 Form B 3 Form A/3 Form B	
Max. operating speed	20 cpm (at nominal voltage)			
Initial insulation resistance*1	Min. 1,000 MΩ at 500 V DC			
Initial breakdown voltage*2	Between open contacts	1,500 Vrms for 1 min.		
	Between contact sets	2,500 Vrms for 1 min.: 7-8/9-10 between open contacts	2,500 Vrms for 1 min.: 7-8/11-12 between open contacts 9-10/13-14 between open contacts 11-12/13-14 between open contacts	
		4,000 Vrms for 1 min.: 3-4/5-6 between open contacts 3-4/7-8 between open contacts 5-6/9-10 between open contacts	4,000 Vrms for 1 min.: 3-4/5-6 between open contacts 3-4/7-8 between open contacts 5-6/9-10 between open contacts 7-8/9-10 between open contacts	
Between contact and coil	4,000 Vrms for 1 min.			
Operate time (at nominal voltage)	Max. 20 ms*3			
Response time*4 (without diode) (at nominal voltage)	Max. 8 ms*3			
Release time (without diode) (at nominal voltage)	Max. 20 ms*3			
Shock resistance	Functional*5	Min. 200 m/s ²		
	Destructive*6	Min. 1,000 m/s ²		
Vibration resistance	Functional*7	10 to 55 Hz at double amplitude of 1.5 mm		
	Destructive	10 to 55 Hz at double amplitude of 1.5 mm		
Conditions for operation, transport and storage*8 (Not freezing and condensing at low temperature)	Ambient temp.	-40°C to +85°C -40°F to +185°F		
	Humidity	5 to 85% R.H.		
Unit weight	Approx. 20 g Approx. .71 oz		Approx. 23 g Approx. .81 oz	

• Outline of performance [Socket for PC board/DIN terminal socket]

Max. carrying current	6 A (Reduce by 0.1 A/°C for temperatures 70 to 85°C.)
Initial breakdown voltage	Between each terminal: 2,500 Vrms for 1 min. (Detection current: 10mA)
Initial insulation resistance*1	Min. 1,000 MΩ at 500V DC

*1 Measurement at same location as "Initial breakdown voltage" section

Remarks

*1 Measurement at same location as "Initial breakdown voltage" section

*2 Detection current: 10mA

*3 Excluding contact bounce time

*4 Response time is the time after the coil voltage turns off until the time when "a" contact turns off.

*5 Half-wave pulse of sine wave: 11ms; detection time: 10μs

*6 Half-wave pulse of sine wave: 6ms

*7 Detection time: 10μs

*8 Refer to 6. Conditions for operation, transport and storage mentioned in AMBIENT ENVIRONMENT

ORDERING INFORMATION

Ex. SF S - - -

Product name	Contact arrangement	Operation indication	Coil voltage
Slim type	2: 2 Form A/2 Form B 3: 3 Form A/1 Form B 4: 4 Form A/2 Form B 5: 5 Form A/1 Form B 6: 3 Form A/3 Form B	Nil: Without LED indication L: With LED indication	DC12, 24, 48V

Note: Standard packing: Carton 20 pcs. Case 200 pcs. (Accessories: Carton 10 pcs. Case 100 pcs.)
Please inquire about other coil voltages.

TYPES

1. Relay

Contact arrangement		Nominal voltage	Without LED indication	With LED indication
			Part No.	Part No.
4-poles	2 Form A/2 Form B	12 V DC	SFS2-DC12V	SFS2-L-DC12V
		24 V DC	SFS2-DC24V	SFS2-L-DC24V
		48 V DC	SFS2-DC48V	SFS2-L-DC48V
	3 Form A/1 Form B	12 V DC	SFS3-DC12V	SFS3-L-DC12V
		24 V DC	SFS3-DC24V	SFS3-L-DC24V
		48 V DC	SFS3-DC48V	SFS3-L-DC48V
6-poles	4 Form A/2 Form B	12 V DC	SFS4-DC12V	SFS4-L-DC12V
		24 V DC	SFS4-DC24V	SFS4-L-DC24V
		48 V DC	SFS4-DC48V	SFS4-L-DC48V
	5 Form A/1 Form B	12 V DC	SFS5-DC12V	SFS5-L-DC12V
		24 V DC	SFS5-DC24V	SFS5-L-DC24V
		48 V DC	SFS5-DC48V	SFS5-L-DC48V
	3 Form A/3 Form B	12 V DC	SFS6-DC12V	SFS6-L-DC12V
		24 V DC	SFS6-DC24V	SFS6-L-DC24V
		48 V DC	SFS6-DC48V	SFS6-L-DC48V

2. Accessories

Type	No. of poles	Part No.
PC board sockets	4-poles	SFS4-PS
	6-poles	SFS6-PS
DIN terminal socket	4-poles	SFS4-SFD
	6-poles	SFS6-SFD

COIL DATA (at 20°C 68°F)

Contact arrangement		Nominal voltage, V DC	Pick-up voltage, V DC (max.) (initial)	Drop-out voltage, V DC (min.) (initial)	Nominal operating current, mA ($\pm 10\%$)	Coil resistance Ω ($\pm 10\%$)	Nominal operating power, mW	Max. allowable voltage, V DC
4-poles	2 Form A/2 Form B	12	9	0.9	30	400	Approx. 360	13.2
		24	18	2.4	15	1,600		26.4
		48	36	4.8	7.5	6,400		52.8
	3 Form A/1 Form B	12	9	0.9	30	400		13.2
		24	18	2.4	15	1,600		26.4
		48	36	4.8	7.5	6,400		52.8
6-poles	4 Form A/2 Form B	12	9	0.9	41.7	288	Approx. 500	13.2
		24	18	2.4	20.8	1,152		26.4
		48	36	4.8	10.4	4,608		52.8
	5 Form A/1 Form B	12	9	0.9	41.7	288		13.2
		24	18	2.4	20.8	1,152		26.4
		48	36	4.8	10.4	4,608		52.8
	3 Form A/3 Form B	12	9	0.9	41.7	288		13.2
		24	18	2.4	20.8	1,152		26.4
		48	36	4.8	10.4	4,608		52.8

Note: The nominal operating current of the LED indication type increases approximately 2 mA because of the light emitting diode display.

DIMENSIONS

1. 4-poles (2 Form A/2 Form B, 3 Form A/1 Form B)

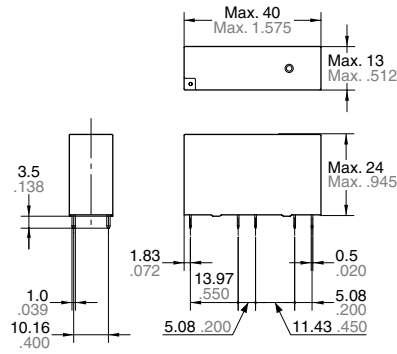
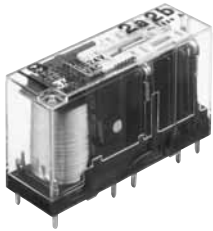

PC board pattern (Bottom view)

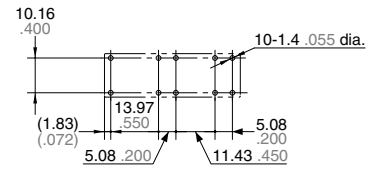

Tolerance: $\pm 0.1 \pm .004$

General tolerance: $\pm 0.3 \pm .012$

Schematic (Bottom view)

Standard

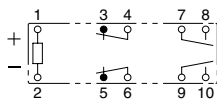

(2 Form A/2 Form B)

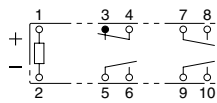

(3 Form A/1 Form B)

With LED indication

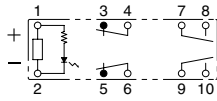

(2 Form A/2 Form B)

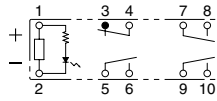

(3 Form A/1 Form B)

2. 6-poles (4 Form A/2 Form B, 5 Form A/1 Form B, 3 Form A/3 Form B)

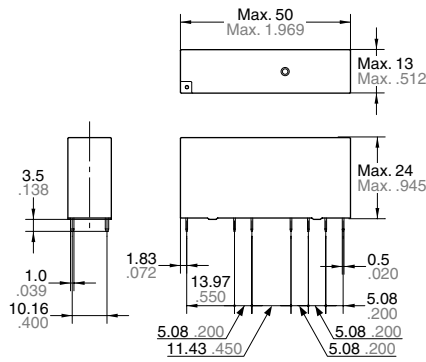
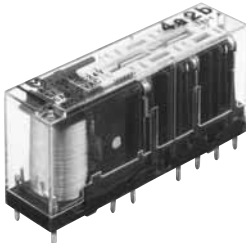

PC board pattern (Bottom view)

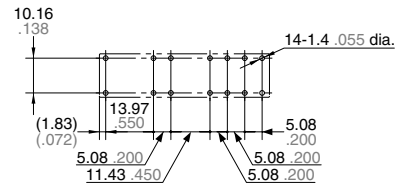

Tolerance: $\pm 0.1 \pm .004$

General tolerance: $\pm 0.3 \pm .012$

Schematic (Bottom view)

Standard

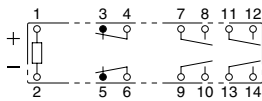

(4 Form A/2 Form B)

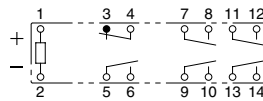

(5 Form A/1 Form B)

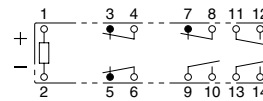

(3 Form A/3 Form B)

With LED indication

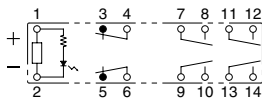

(4 Form A/2 Form B)

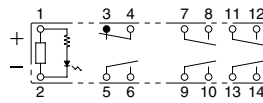

(5 Form A/1 Form B)

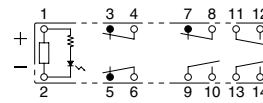

(3 Form A/3 Form B)

3. PC board sockets (4-poles)

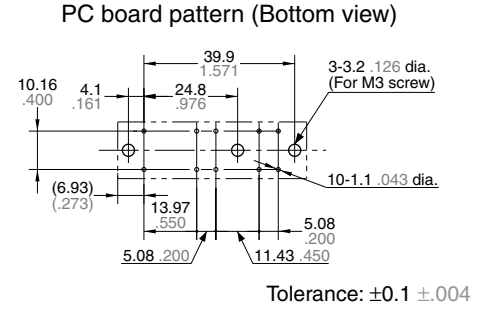
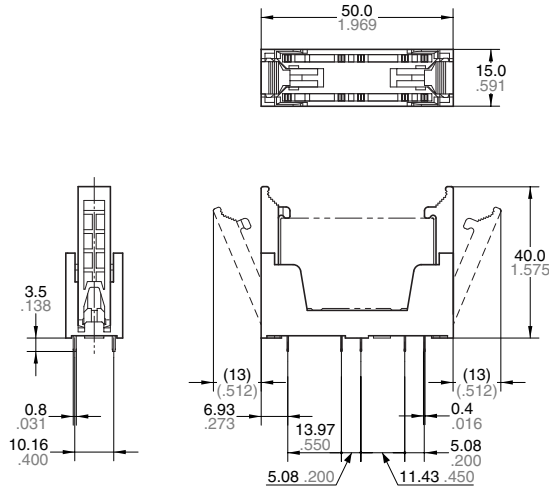
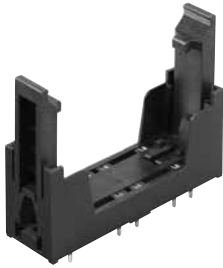

General tolerance: $\pm 0.3 \pm .012$

Schematic (Bottom view)

Standard

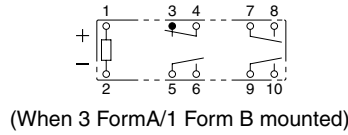
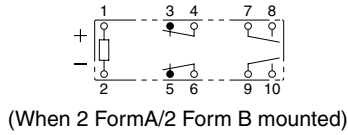

With LED indication

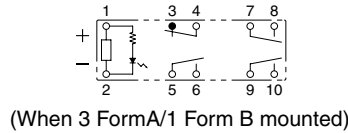
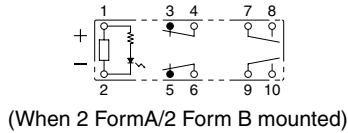

4. PC board sockets (6-poles)

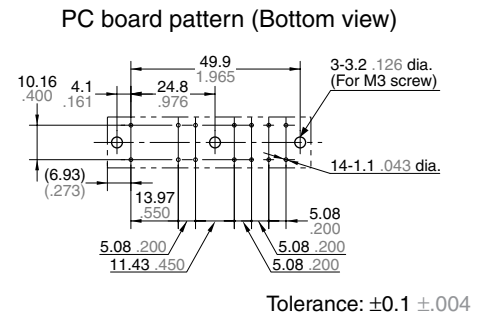
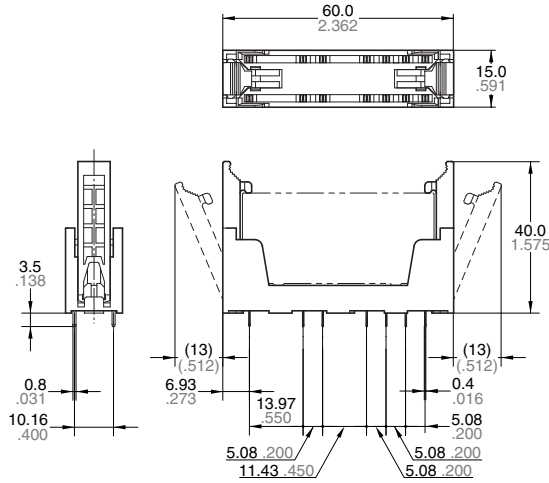
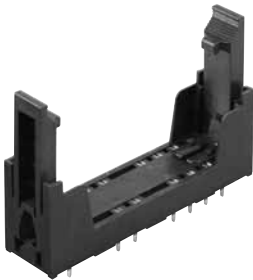

General tolerance: $\pm 0.3 \pm .012$

Schematic (Bottom view)

Standard

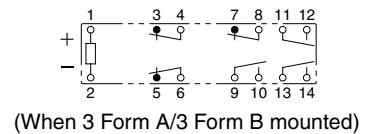
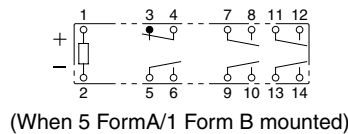
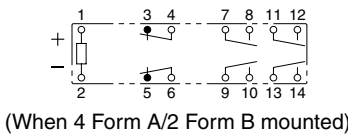

With LED indication

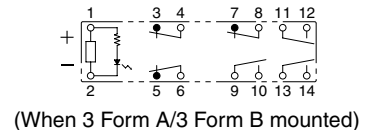
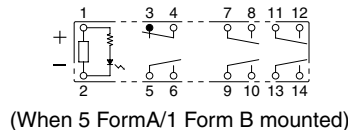
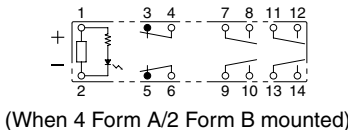

5. DIN terminal socket (4-poles)

mm inch

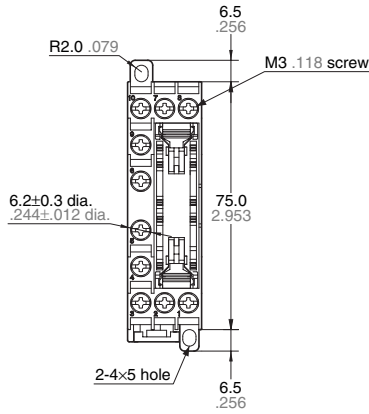
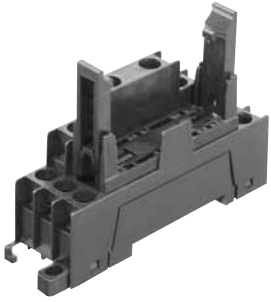

Mounting hole dimensions

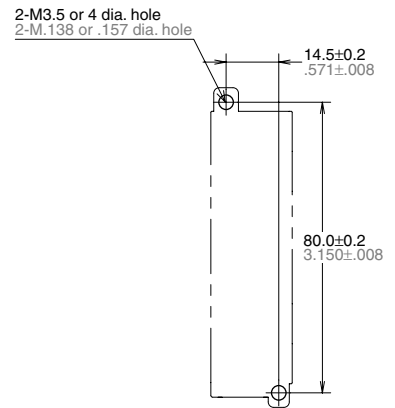

Tolerance: ±0.1 ±.004

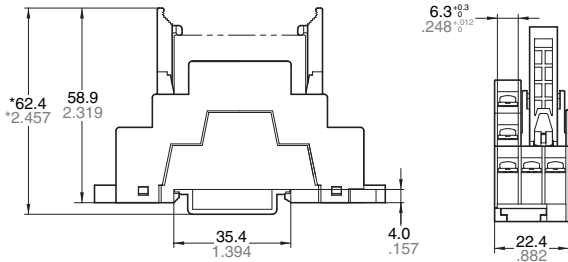

General tolerance: ±0.5 ±.020

Schematic (Top view)

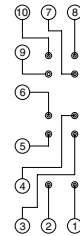

* Reference value (when using DIN rail ATA48011)

Note: Round terminals cannot be used with DIN terminal sockets.

6. DIN terminal socket (6-poles)

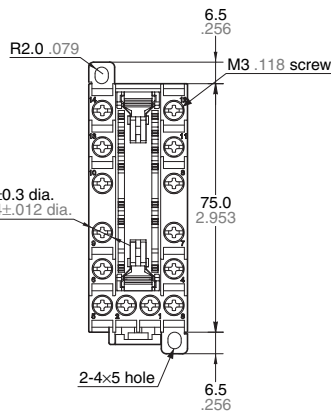
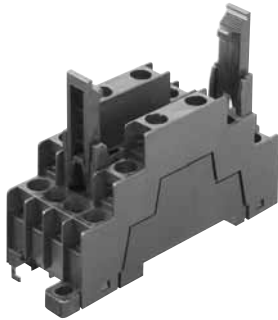

Mounting hole dimensions

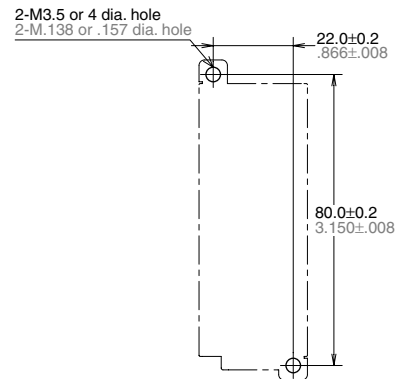

Tolerance: ±0.1 ±.004

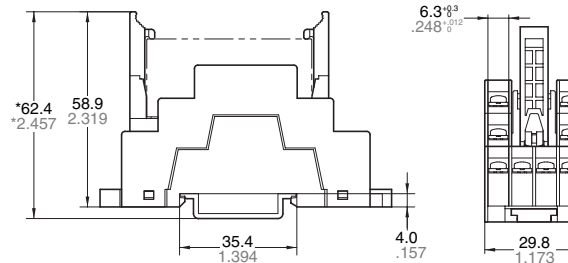

General tolerance: ±0.5 ±.020

Schematic (Top view)

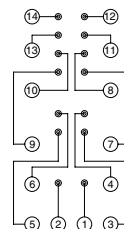

* Reference value (when using DIN rail ATA48011)

Note: Round terminals cannot be used with DIN terminal sockets.